

Drywall Pro-Cut Ltd

Office Drywall Supplies: Drywall Components Now Made Off Site by the Expert Drywall Distributor.

Head Office: Villiers Court, Meriden Business Park, 7 Copse Dr, Millisons Wood, Coventry, CV5 9RN.

Tel: 07740 358 514

Email: enquiries@drywallpro-cut.co.uk

Website: <https://www.drywallpro-cut.co.uk>

PRODUCT PROFILE

Door set designed to form metal framing for standard door openings in British Gypsum partitioning systems. Drywall Pro-Cut source all necessary metal components in the form of head, feet and sleeve channels to meet specifications and comply with British Gypsum system warranties. Components are available in bespoke sizes as required by the client and are machine cut to precise dimensions from manufacturer approved metal sections to guarantee high levels of quality. Door sets comply with standard British Gypsum detailing for Light and Medium Duty or Heavy and Severe Duty door frames as required. Door sets accommodate a range of specification requirements and guarantee an effective platform for the carpentry interface to produce a high-quality finish.

MATERIAL SPECIFICATION, DIMENSIONS AND SIZES

Material Properties and Available Dimensions for Metal Track Components

*Material properties for metal components comply to standards detailed in BS EN 14195:2005.

*Standard details available from British Gypsum for door sets (maximum 1200mm width) to satisfy BS 5234: Parts 1 and 2: 1992.

*For fire and performance rating of partitions where door set will be used see full British Gypsum specifications for selected partitioning systems.

*It is recommended to seek advice from door manufacturer and acoustic consultants before constructing project specific details.

Metal Track Selections	Length	Width	Flange Depth	Gauge Thickness	Reaction to Fire	Yield Strength	Metal Unit Weight
Gypframe® 50FEC50	Bespoke	50mm	29mm	0.50mm	A1	210N/mm ²	0.44kg/lm
Gypframe® 72FEC50	Bespoke	72mm	29mm	0.50mm	A1	210N/mm ²	0.52kg/lm
Gypframe® 94FEC50	Bespoke	94mm	29mm	0.50mm	A1	210N/mm ²	0.61kg/lm
Gypframe® 148FEC50	Bespoke	148mm	29mm	0.50mm	A1	210N/mm ²	0.82kg/lm
Gypframe® 50DC60	Bespoke	50mm	50mm	0.60mm	A1	210N/mm ²	0.70kg/lm
Gypframe® 72DC60	Bespoke	72mm	50mm	0.60mm	A1	210N/mm ²	0.80kg/lm
Gypframe® 94DC60	Bespoke	94mm	50mm	0.60mm	A1	210N/mm ²	0.90kg/lm
Gypframe® 148DC60	Bespoke	148mm	50mm	0.60mm	A1	210N/mm ²	1.16kg/lm
Gypframe® 50EDC70	Bespoke	50mm	70mm	0.70mm	A1	210N/mm ²	1.03kg/lm
Gypframe® 72EDC80	Bespoke	72mm	70mm	0.80mm	A1	210N/mm ²	1.31kg/lm
Gypframe® 94EDC70	Bespoke	94mm	70mm	0.70mm	A1	210N/mm ²	1.27kg/lm
Gypframe® 148EDC80	Bespoke	148mm	70mm	0.80mm	A1	210N/mm ²	1.78kg/lm

ADDITIONAL PRODUCT DETAILS

- Door sets available to comply with Light and Medium Duty British Gypsum details (up to 35kg door) to BS 5234:1992.
- Door sets available to comply with Heavy and Severe Duty British Gypsum details (up to 60kg door) to BS 5234: 1992.
- Metal sections all meet BS EN 14195:2014 requirements for metal framing components for gypsum board systems.
- Door frames comply with standard details to BS 5234: Parts 1 and 2 provided that structural opening widths do not exceed 1200mm (for openings above this width lintel details may be required).
- Gypframe metal channels are cold-roll formed from DX51D+Z140 NA-C Galvanised Steel.
- Gypframe metal channels are 100% recyclable (European Waste Catalogue code is 12 01 01).
- Gypframe metal channels all have BES6001 Classification: Excellent.
- Component is capable of compliance with British Gypsum SpecSure® warranty verifying that approved partitioning systems will perform as specified upon installation and will continue to do so throughout the design life of the building.

INSTALLATION, QUALITY AND ADDITIONAL INFORMATION

- All components are fabricated off site in a quality-controlled environment before being delivered safely to site.
- See project-specific British Gypsum detailing for specified partitioning systems for guidelines on site installation.
- Door frames are supplied containing head, legs and sleeves to specifications as necessary for simple on-site fixing.
- Components ensure compliance with standard British Gypsum detailing dimensions for head and leg upstands.

Drywall Pro-Cut Ltd

Drywall Pro-Cut Door Set: Standard Detailing of Components Supplied for On-Site Installation

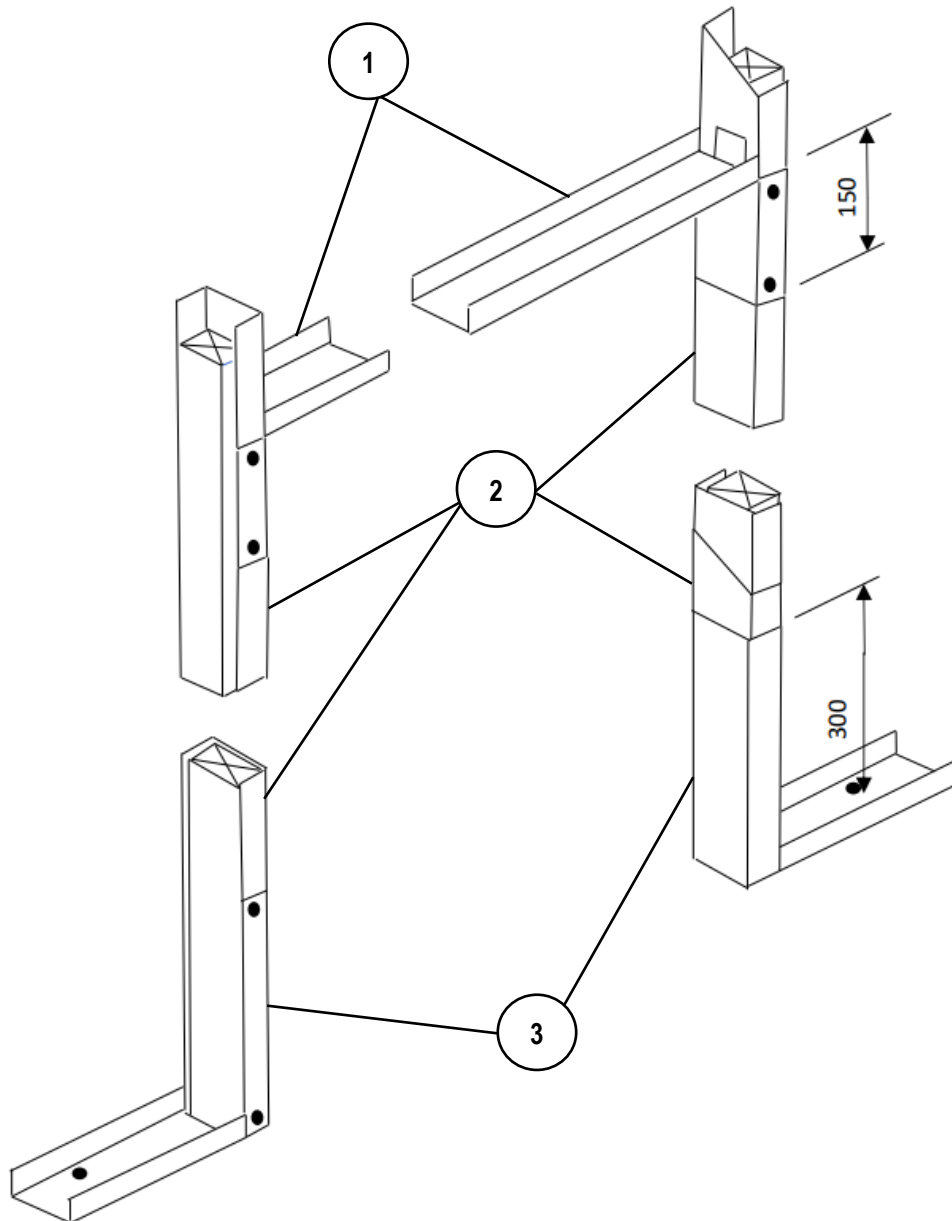

1. Door Head comprised of Gypframe metal track as specified.
 2. Door sleeves (as required) comprised of Gypframe metal track as specified.
 3. Door Legs (as required) comprised of Gypframe metal track as specified.
- **Note:** Door frames are available in compliance with Light and Medium or Heavy and Severe Duty Ratings as specified in accordance with standard British Gypsum details.
 - **Note:** Lintel details are typically advised for door heads exceeding 1200mm in width.
 - **Note:** Additional requirements including specified timber infills may be mandated in accordance with door manufacturer specifications.
 - **See Website:** <https://www.drywallpro-cut.co.uk> for available options.

Drywall Pro-Cut Ltd

Office Drywall Supplies: Drywall Components Now Made Off Site by the Expert Drywall Distributor.

Head Office: Villiers Court, Meriden Business Park, 7 Copse Dr, Millisons Wood, Coventry, CV5 9RN.

Tel: 07740 358 514

Email: enquiries@drywallpro-cut.co.uk

Website: <https://www.drywallpro-cut.co.uk>