

## Drywall Pro-Cut Ltd

Office Drywall Supplies: Drywall Components Now Made Off Site by the Expert Drywall Distributor.

**Head Office:** Villiers Court, Meriden Business Park, 7 Copse Dr, Millisons Wood, Coventry, CV5 9RN.

**Tel:** 07740 358 514

**Email:** [enquiries@drywallpro-cut.co.uk](mailto:enquiries@drywallpro-cut.co.uk)

**Website:** <https://www.drywallpro-cut.co.uk>

## PRODUCT PROFILE

Door set designed to form metal framing for standard door openings in Siniat partitioning systems. Drywall Pro-Cut source, assess and shape all necessary metal components in the form of head, feet and sleeve channels to meet specifications and facilitate compliance with Siniat system warranties. Components are available in bespoke sizes as required and are machine cut and shaped to precise dimensions from manufacturer approved metal sections to guarantee high levels of quality. Door sets comply with standard Siniat detailing for supporting doors of up to 100kg (in bands of 35kg, 60kg and 100kg) as required to accommodate a range of specification needs and guarantee an effective platform for the later carpentry interface to produce a high-quality finish.

## MATERIAL SPECIFICATION, DIMENSIONS AND SIZES

### Material Properties and Available Dimensions for Metal and Plasterboard Components

\*Material properties for metal components comply to standards detailed in BS EN 14195:2005.

\*Standard details available from Siniat for door frames (maximum 1200mm width) to support doors of up to 35kg, 60kg or 100kg as required.

\*For fire and performance rating of partitions where door sets will be used see full Siniat specifications for selected partitioning systems.

\*It is recommended to seek advice from the specific door manufacturer and acoustic consultants before constructing project specific details.

Metal Track Selections	Length	Width	Flange Depth	Gauge Thickness	Reaction to Fire	Yield Strength	Metal Unit Weight
GTEC UT52/RX	Bespoke	52mm	27mm	0.5mm	A1	NPD	0.44kg/lm
GTEC UT72/RX	Bespoke	72mm	27mm	0.5mm	A1	NPD	0.53kg/lm
GTEC UT92/RX	Bespoke	92mm	27mm	0.5mm	A1	NPD	0.62kg/lm
GTEC UT148/RX	Bespoke	148mm	27mm	0.5mm	A1	NPD	0.85kg/lm
GTEC UDT52/B	Bespoke	52mm	50mm	0.6mm	A1	NPD	0.82kg/lm
GTEC UDT72/B	Bespoke	72mm	50mm	0.6mm	A1	NPD	0.87kg/lm
GTEC UDT92/B	Bespoke	92mm	50mm	0.6mm	A1	NPD	1.04kg/lm
GTEC UDT148/B	Bespoke	148mm	50mm	0.6mm	A1	NPD	1.34kg/lm
GTEC UXT72/B	Bespoke	72mm	70mm	0.7mm	A1	NPD	1.15kg/lm
GTEC UXT92/W	Bespoke	92mm	70mm	0.9mm	A1	NPD	1.61kg/lm
GTEC UXT148/W	Bespoke	148mm	70mm	0.9mm	A1	NPD	2.01kg/lm

## ADDITIONAL PRODUCT DETAILS

- Door sets available to comply with standard Siniat details estimated to be effective for supporting doors of up to 35kg, 60kg or 100kg as required (see section PT-CS-401P and PT-CS-403E of Siniat Drywall Manual).
- Door suppliers should be consulted to ensure that standard Siniat details comply with tested solutions.
- Metal sections all meet BS EN 14195:2014 requirements for metal framing components for gypsum board systems.
- For opening widths of over 1200mm lintel details are typically advised to be used instead of standard details.
- Siniat components are BRE Green Guide A/A+ rated and help collect sustainability code credits.
- Gypframe metal channels are 100% recyclable provided they are properly separated from other construction components.
- Component capable of compliance with Etex Siniat GTEC warranty verifying that approved partitioning systems will perform as specified for 10 years from the date of purchase of the relevant board or component when installed correctly.
- Component capable of compliance with Siniat Lifetime System warranties depending on site specific details.

## INSTALLATION, QUALITY AND ADDITIONAL INFORMATION

- All components and fabricated off site by Drywall Pro-Cut in a quality-controlled environment for safe delivery to site.
- See project specific Siniat detailing for specified partitioning systems for guidelines on site installation.
- Additional components including timber infills or additional jamb studs may be required depending on door manufacturer.
- Door frames are supplied containing head, legs and sleeves to specifications as necessary for simple on-site fixing.
- Components ensure compliance with standard Siniat detailing dimensions for head and leg upstands.

## Drywall Pro-Cut Ltd

## Drywall Pro-Cut Door Set: Standard Detailing of Components Supplied for On-Site Installation

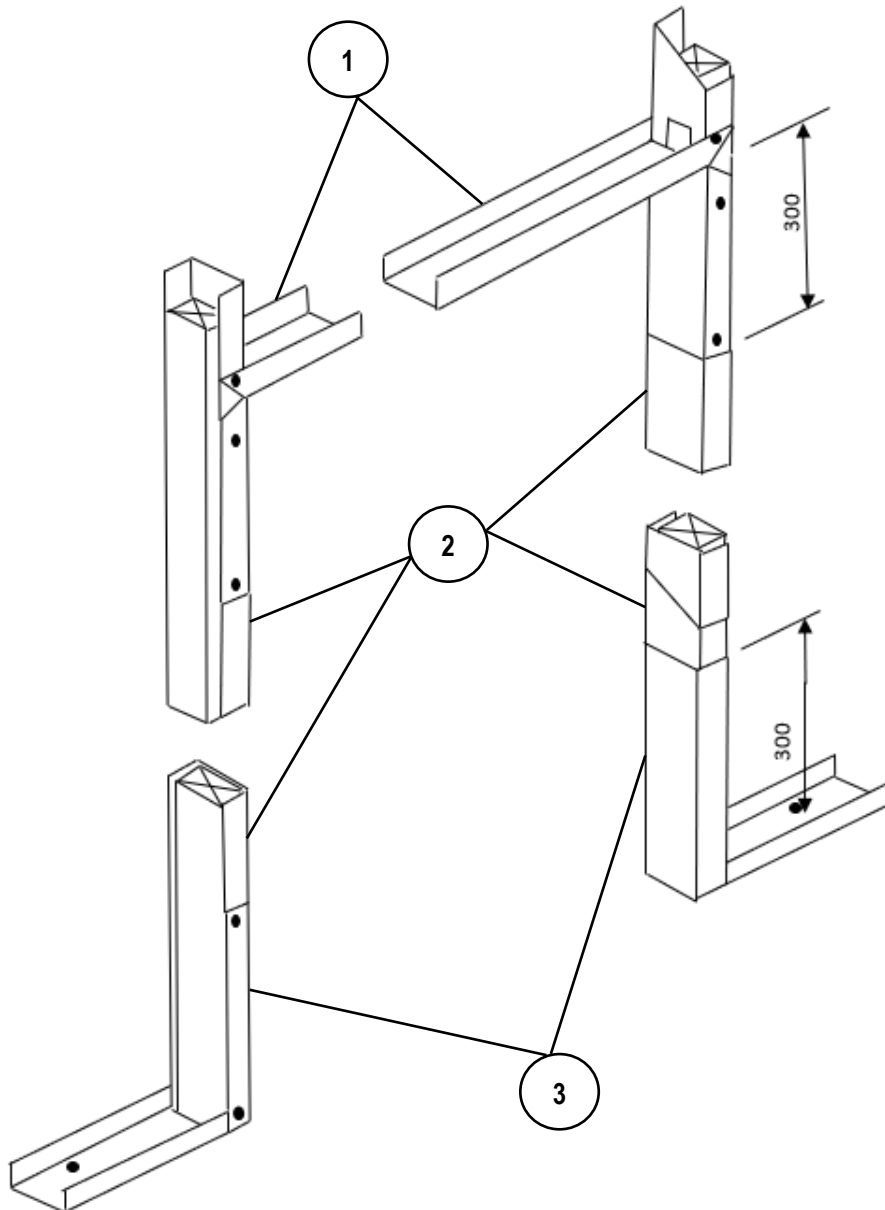

1. **Door head** comprised of GTEC metal track as specified.
2. **Door sleeves** (as required) comprised of GTEC metal track as specified.
3. **Door legs** (as required) comprised of GTEC metal track as specified.

- **Note:** Door frames are available in compliance with 35kg, 60kg and 100kg duty ratings as specified by Siniat.
- **Note:** Deep Flange U Track is typically mandated for door weights exceeding 35kg, whilst additional jamb studs are required for door weights exceeding 60kg.
- **Note:** Additional requirements including specified timber infills may be mandated in accordance with door manufacturer specifications.
- **See Website:** <https://www.drywallpro-cut.co.uk> for available options.

**Drywall Pro-Cut Ltd**

Office Drywall Supplies: Drywall Components Now Made Off Site by the Expert Drywall Distributor.

**Head Office:** Villiers Court, Meriden Business Park, 7 Copse Dr, Millisons Wood, Coventry, CV5 9RN.

**Tel:** 07740 358 514

**Email:** [enquiries@drywallpro-cut.co.uk](mailto:enquiries@drywallpro-cut.co.uk)

**Website:** <https://www.drywallpro-cut.co.uk>