

Drywall Pro-Cut Ltd

Office Drywall Supplies: Drywall Components Now Made Off Site by the Expert Drywall Distributor.

Head Office: Villiers Court, Meriden Business Park, 7 Copse Dr, Millisons Wood, Coventry, CV5 9RN.

Tel: 07740 358 514

Email: enquiries@drywallpro-cut.co.uk

Website: <https://www.drywallpro-cut.co.uk>

PRODUCT PROFILE

3-Sided flat-packed component designed to form an opening within Siniat single-frame metal stud partitions enabling penetration of services through the partition to reach adjoining spaces. Accommodates a range of bespoke opening sizes with allowance for building deflection to form a specified service opening flush to the underside of the soffit. Fabricated in an offsite environment to maximise safety and ensure high levels of quality and compliance with associated regulatory requirements and manufacturer warranties. Complies with all thermal and acoustic requirements as a critical component of the extensive range of Siniat partitioning systems whilst providing high levels of protection against fire for periods of up to 120 minutes in standard applications.

MATERIAL SPECIFICATION, DIMENSIONS AND SIZES**Material Properties and Available Dimensions for Metal and Plasterboard Components**

*Thermal and fire material testing carried out by Siniat in accordance with EN 520:2004+A1:2009.

*Material properties were tested as based on individual metal and gypsum components, not for the entire component.

*For fire rating of partitions containing this product see BS EN 1366-3 and full Siniat specifications for selected partitioning systems.

Metal Track Selections	Length	Width	Flange Depth	Gauge Thickness	Metal Unit Weight
Siniat UDT52/B	As Required	52mm	50mm	0.6mm	0.82kg/m
Siniat UDT62/B	As Required	62mm	50mm	0.6mm	0.93kg/m
Siniat UDT72/B	As Required	72mm	50mm	0.6mm	0.87kg/m
Siniat UDT92/B	As Required	92mm	50mm	0.6mm	1.04kg/m
Siniat UDT148/B	As Required	148mm	50mm	0.6mm	1.34kg/m
Siniat UXT72/B	As Required	72mm	70mm	0.7mm	1.15kg/m
Siniat UXT92/W	As Required	92mm	70mm	0.9mm	1.61kg/m
Siniat UXT148/W	As Required	148mm	70mm	0.9mm	2.01kg/m
Plasterboard Selections	Reaction to Fire	Thermal Conductivity	Minimum Weight	No of Layers	
12.5mm Standard Board	A2-s1, d0	0.19W/mK	8.0kg/m ²	1 or 2	
15mm Standard Board	A2-s1, d0	0.19W/mK	10.0kg/m ²	1 or 2	
12.5mm dB Board	A2-s1, d0	0.25W/mK	11.0kg/m ²	1 or 2	
15mm dB Board	A2-s1, d0	0.25W/mK	13.0kg/m ²	1 or 2	
12.5mm Fire Board	A2-s1, d0	0.25W/mK	10.2kg/m ²	1 or 2	
15mm Fire Board	A2-s1, d0	0.25W/mK	12.3kg/m ²	1 or 2	
12.5mm Moisture Board	A2-s1, d0	0.25W/mK	9.0kg/m ²	1 or 2	
15mm Moisture Board	A2-s1, d0	0.25W/mK	11.9kg/m ²	1 or 2	
12.5mm Megadeco	A2-s1, d0	0.25W/mK	11.0kg/m ²	1 or 2	
15mm Megadeco	A2-s1, d0	0.25W/mK	13.0kg/m ²	1 or 2	

ADDITIONAL PRODUCT DETAILS

- Full penetration design using third-party fire stopping material should also reference BS EN 1366-3 to properly assess penetration fire resistance properties in addition to any basic test data provided by Siniat to BS EN 1364-1.
- Metal sections all meet BS EN 14195:2005 requirements for metal framing components for gypsum board systems.
- Installation in accordance with Siniat recommendations using appropriate third-party BS EN 1366-3 compliant fire stopping material should achieve full fire rating performance for any specified British Gypsum partitioning system.
- FSI STOPSEAL® is Siniat-approved for third-party fire stopping with warranties available (see specific system guidance).
- Fire testing of full partitioning systems containing this product or equivalent conducted according to BS EN1364-1:1999.
- Siniat components are BRE Green Guide A/A+ rated and help collect sustainability code credits.
- GTEC metal channels are 100% recyclable provided they are properly separated from other construction components.
- Gypsum based components can be fully recycled provided they are not contaminated by non-gypsum materials.

Drywall Pro-Cut Ltd

INSTALLATION, QUALITY AND ADDITIONAL INFORMATION

- All materials and fixings are installed off site in a quality-controlled environment and delivered safely to site.
- See project-specific Siniat detailing for specified partitioning systems for guidelines on site installation.
- Additional fire protection in the form of Gyproc Intumescent Acoustic Sealant is applied between boards/metal as required.
- Adjustable Builder's Work Openings are available in a range of bespoke sizes for accurate positioning at any location across the partition section (with accompanying support legs also being supplied and delivered as specified).
- Modular Builder's Work Openings are also available for simple and efficient installation between specified stud centres.
- Installation in accordance with Siniat guidance is capable of matching full structural, thermal, fire and acoustic properties for partitioning systems as specified in Siniat system level test data with additional reference to BS EN 1366-3.

ADJUSTABLE AND MODULAR BUILDER'S WORK OPENING DETAILS KEY

1. **Plasterboard fillets** as specified.
2. **Metal head track** as specified to comprise opening.
3. **Metal track** to comprise support legs as required.

Drywall Pro-Cut 3-Sided Builder's Work Opening: Adjustable Variant (Standard Detail)

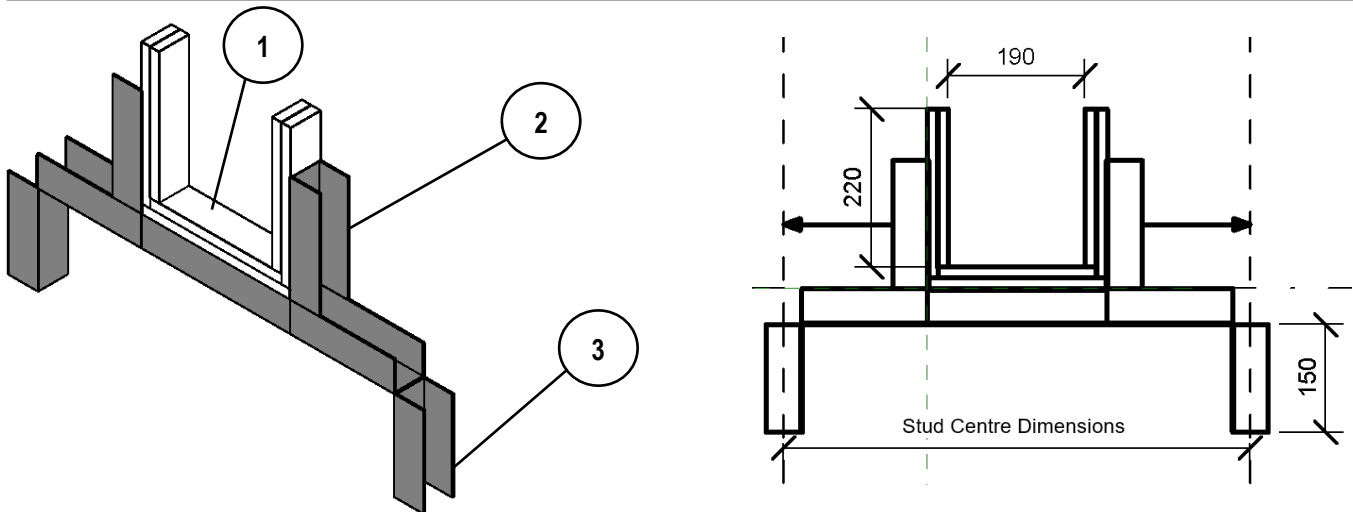

***Note:** Support legs are provided to fit to the specified stud centres. Stock centre sizes include: 400, 600 and 1200mm c/c.

***Note:** Support legs are utilised to enable fixing of the adjustable opening to vertical studs within the partition.

***Note:** The opening location can be adjusted horizontally across the length of the support leg to enable the flexible positioning.

Drywall Pro-Cut 3-Sided Builder's Work Opening: Modular Variant (Standard Detail)

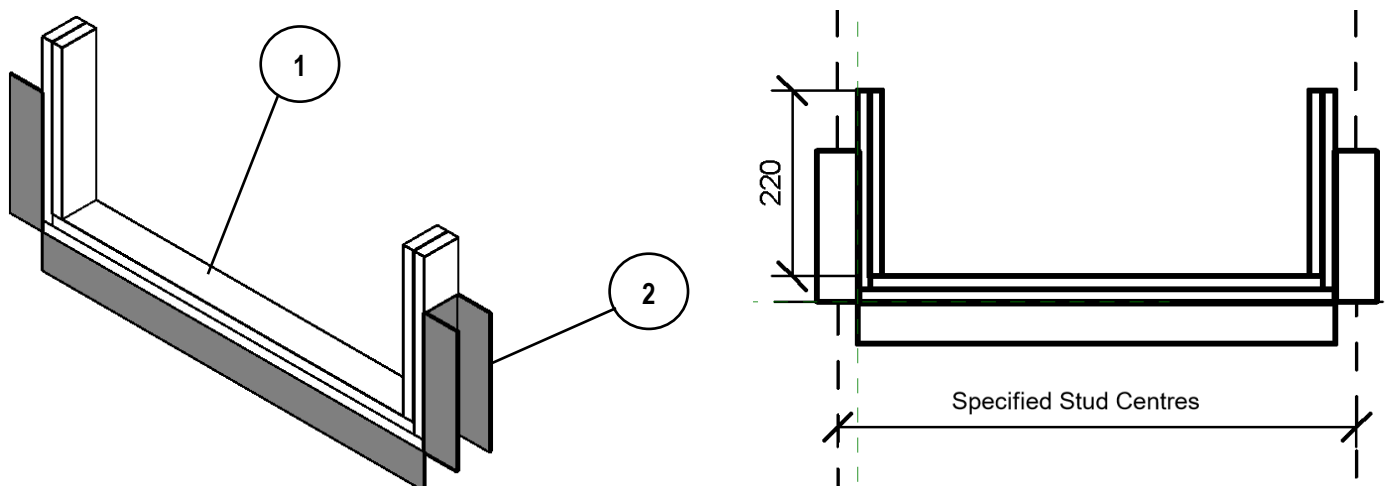

***Note:** Modular openings can be produced to be fixed directly to vertical studs as a single composite member without the need for additional support legs. If more flexible opening dimensions are required then adjustable openings should be selected.

Drywall Pro-Cut Ltd

Drywall Pro-Cut 3-Sided Builder's Work Opening: Standard Siniat Compliant Detail

1. Plasterboard fillets as specified.
 2. Metal head track as specified.
 3. GTEC Intumescent Acoustic Sealant applied between boards and metal track as required.
- **Note:** Board extension beyond metal legs calculated automatically by Drywall Pro-Cut to account for soffit deflection and ensure proper partition sealing for acoustic and thermal performance specifications and Siniat installation requirements.
 - **Note:** Fixings selected to ensure compliance with Siniat performance criteria.
 - **See Website:** <https://www.drywallpro-cut.co.uk> for available options.

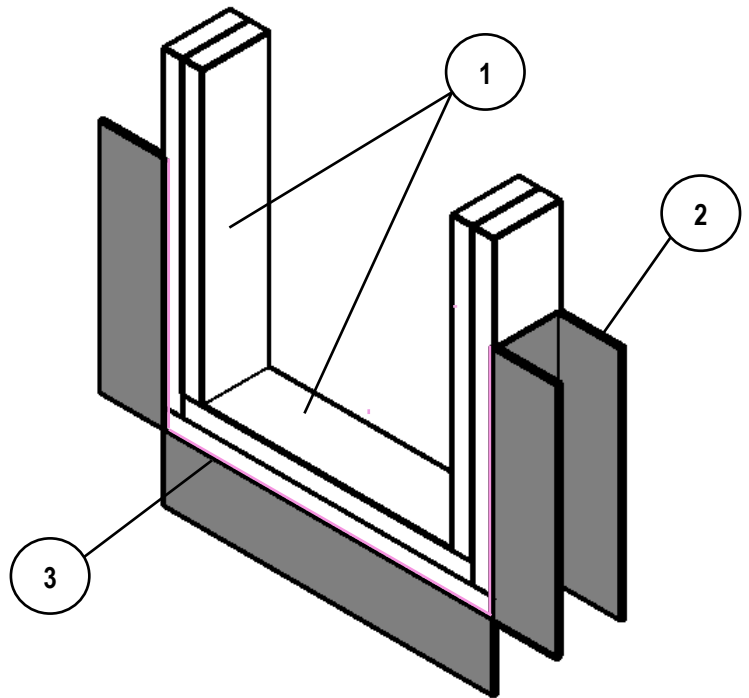

3-Sided Builder's Work Opening: Example Dimensions for Siniat Compliant Opening

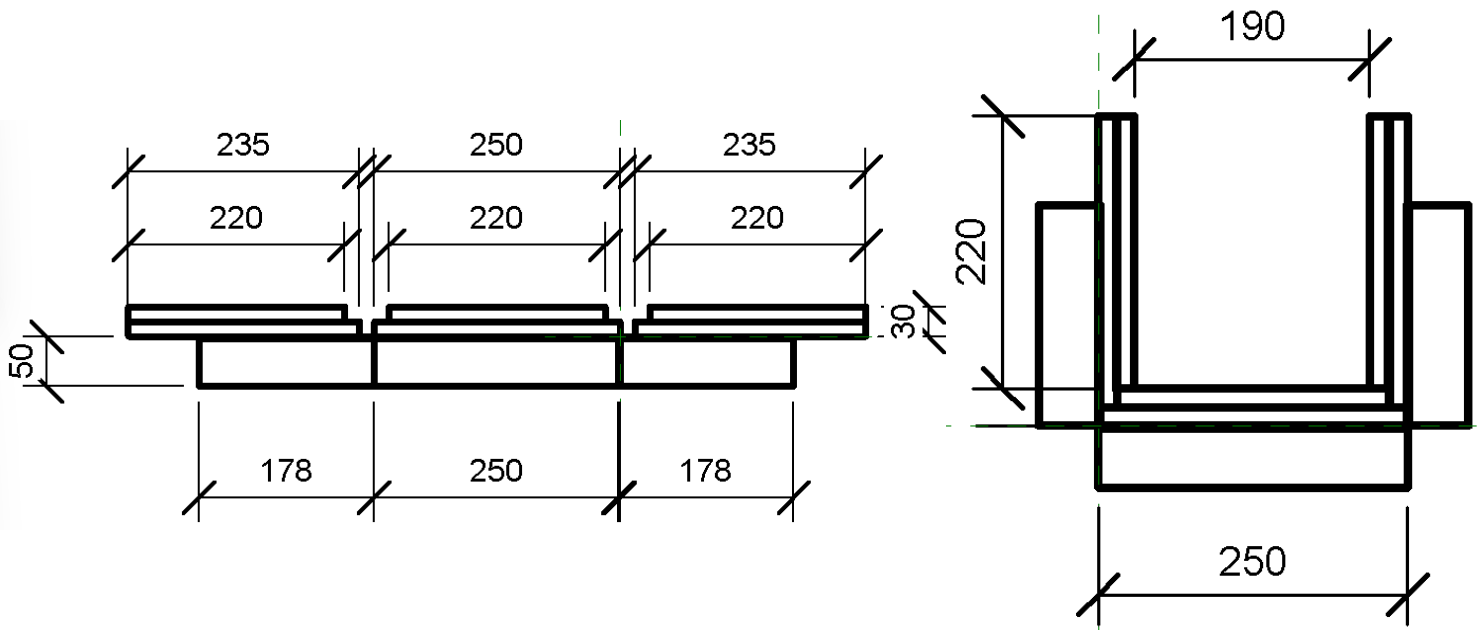

Drywall Pro-Cut Ltd

Office Drywall Supplies: Drywall Components Now Made Off Site by the Expert Drywall Distributor.

Head Office: Villiers Court, Meriden Business Park, 7 Copse Dr, Millisons Wood, Coventry, CV5 9RN.

Tel: 07740 358 514

Email: enquiries@drywallpro-cut.co.uk

Website: <https://www.drywallpro-cut.co.uk>